

Installation:

1st nut should be spanned with 40 - 45Nm.
 2nd nut should shall be brought at least to a snug-tight condition, with special care being given to avoid over-tightening.
 Nut-marking should be made acc. to figure after torque.

Maintenance:

Visual inspection of bolt torque and any loose items is made 1 year after installation, and afterwards every 5th year.
 Check if the marking from bolt torque is still straight.
 Check if the corrosion protection system is satisfactory.
 Any findings must be repaired as soon as possible.

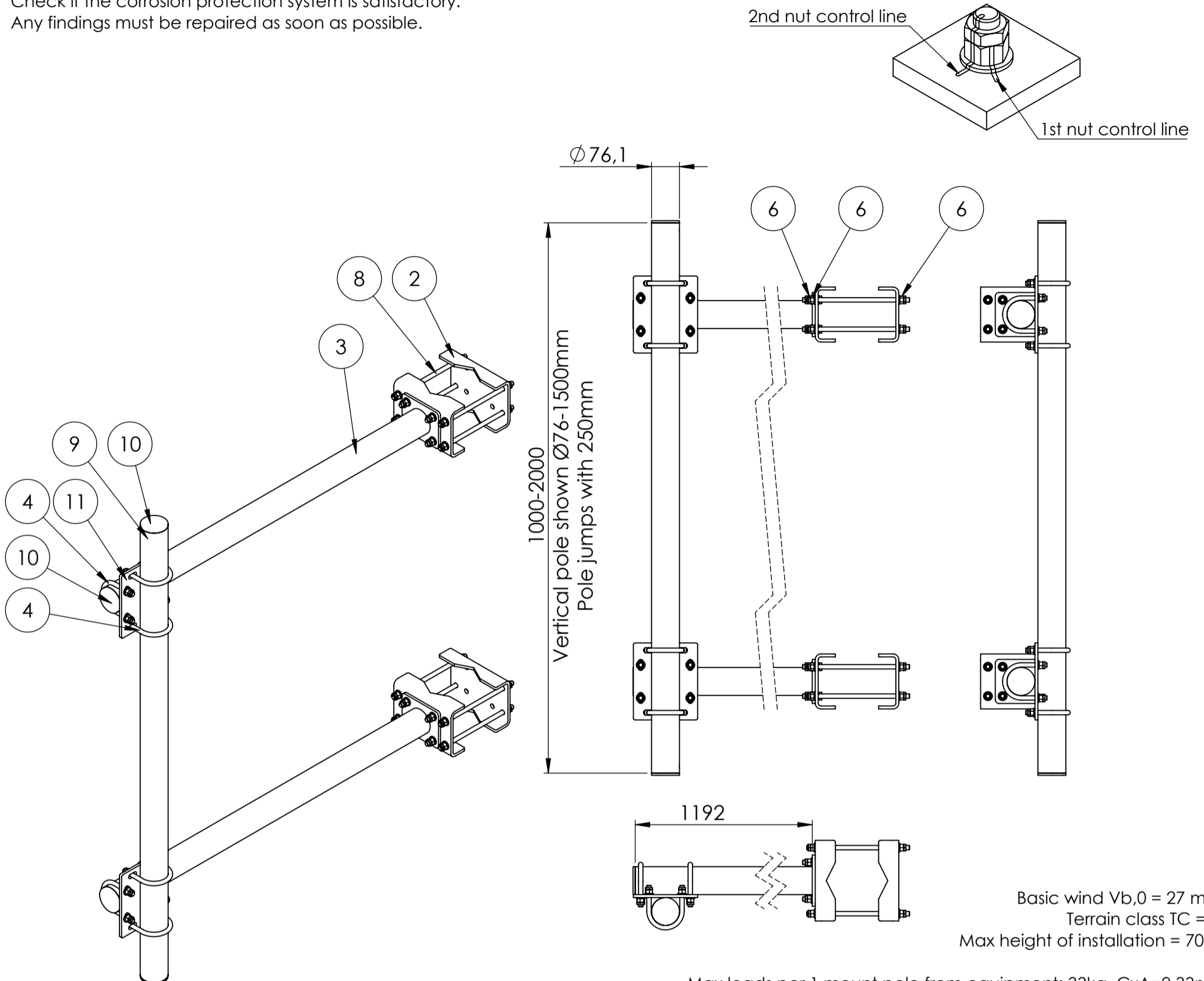

ITEM NO.	PART NUMBER	DESCRIPTION	QTY.
2	CB-Ø90-150 300	C bracket Ø90-150	4
3	CVBM_H1200	Horizontal pole for C and V bracket	2
4	U-bolt M12 C-C = 90		8
5	Washer ISO 7089 - 12		44
6	ISO - 4032 - M12 - W - N		40
7	ISO - 4035 - M12 - N		40
8	M12x280 DIN976	Horizontal pole bracket pin-bolts	8
9	Pole Ø76-1500	Vertical pole Ø76,1 - length: 1500	1
10	GL 76x1.6-4	tubular legs for Ø76,1	4
11	MB-Ø76-76 300	Bracket vertical pole Ø76,1-76,1	2
12	ISO 4017 - M12 x 45-N		8

Rev.:	Int.:	Date:	Comment		
Customer.:					
Subjekt.:		Antenna offset f. Ø90-150 with multi adjustable brackets			
Date.:	22-10-2021	Production no.:	Scale.:	1:12	Format:A3
Order no.:		Calculation:	Int.:	SP/MRF	Projection:
Drawing. No.:	CBM-Ø90-150 H1200	Note.:			
Tolerance: DS/EN 1090-2 DS/ISO 2768-2-L					